

Name: _____

Date: _____

Proving Parallel Lines

Objective

By completing this worksheet, you will be able to use angle relationships to prove if lines cut by a transversal are parallel.

Angle Relationships

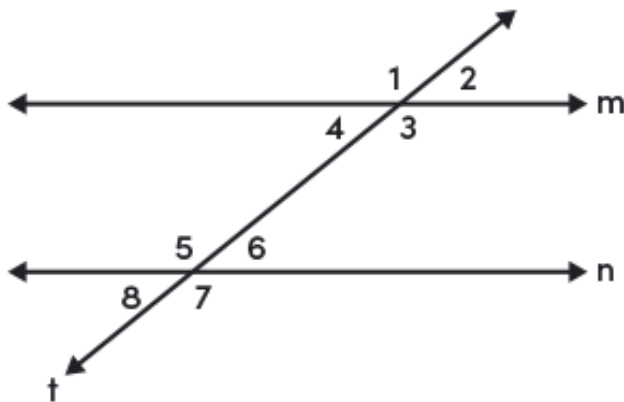

- If two parallel lines are cut by a transversal, then alternate interior angles are congruent.
Examples: $\angle 3$ and $\angle 5$, $\angle 4$ and $\angle 6$
- If two parallel lines are cut by a transversal, then alternate exterior angles are congruent.
Examples: $\angle 1$ and $\angle 7$, $\angle 2$ and $\angle 8$
- If two parallel lines are cut by a transversal, then corresponding angles are congruent.
Examples: $\angle 1$ and $\angle 5$, $\angle 2$ and $\angle 6$, $\angle 3$ and $\angle 7$, $\angle 4$ and $\angle 8$
- If two parallel lines are cut by a transversal, then same-side interior angles are supplementary.
Examples: $\angle 3$ and $\angle 6$, $\angle 4$ and $\angle 5$



The converse of each statement is also true.

- If two lines are cut by a transversal and alternate interior angles are congruent, then the lines are parallel.
- If two lines are cut by a transversal and alternate exterior angles are congruent, then the lines are parallel.
- If two lines are cut by a transversal and corresponding angles are congruent, then the lines are parallel.
- If two lines are cut by a transversal and same-side interior angles are supplementary, then the lines are parallel.

? Question

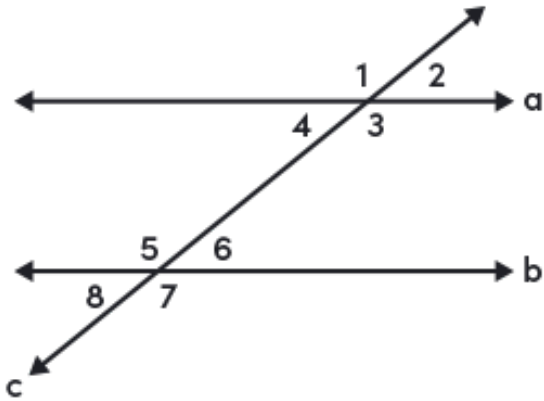

1. If $m\angle 3 = 127^\circ$, what must $m\angle 5$ be equal to for lines a and b to be parallel?

$m\angle 5 = \underline{\hspace{2cm}}^\circ$

2. Complete the proof.

Given: Transversal v cuts lines f and r.

$m\angle 1 + m\angle 2 = 180^\circ$

Prove: $f \parallel r$

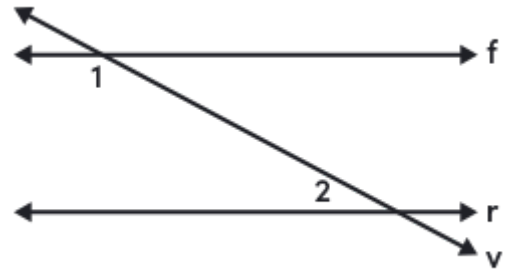

Statements	Reasons
1. $m\angle 1 + m\angle 2 = 180^\circ$	1. given
2. $\angle 1$ and $\angle 2$ are _____.	2. definition of supplementary angles
3. Transversal v cuts lines f and r.	3. _____
4. $f \parallel r$	4. same-side _____ angles theorem converse

Question

3. Complete the diagram below to show that lines c and d are parallel.

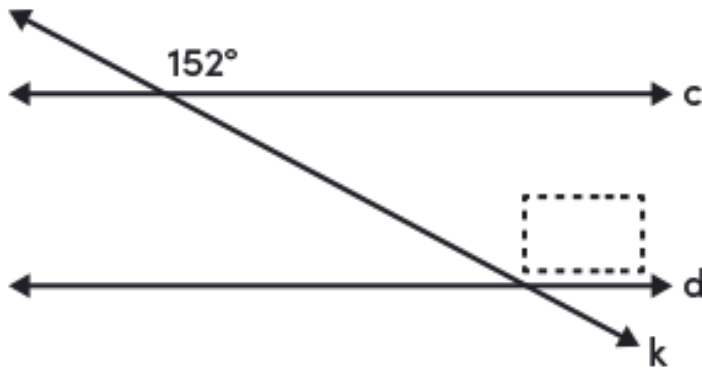

Question

Complete the given statements.

4. If $m\angle 4 = m\angle$ _____, then lines t and u are parallel by the converse of the corresponding angles theorem.
5. If $m\angle 4 = m\angle$ _____, then lines r and s are parallel by the converse of the corresponding angles theorem.
6. If $m\angle 4 = m\angle 14$, then lines t and u are parallel by the converse of the _____ angles theorem.
7. If $m\angle 10 = m\angle 16$, then lines _____ and _____ are parallel by the converse of the alternate exterior angles theorem.
8. If $m\angle 3 + m\angle$ _____ $= 180^\circ$, then lines t and u are parallel by the converse of the same-side interior angles theorem.

